

Recess Effects on Spray Characteristics of Swirl Coaxial Injectors

J.H. Seol*, P.G. Han, W.H. Jeong* and Y. Yoon*****

School of Mechanical and Aerospace Engineering
Seoul National University, Seoul, Korea 151-744

Abstract

Recess is a geometrical configuration shape that the exit surface of an inner injector is located at a certain length inward from that of an outer injector. It is known to have the characteristics that it can augment mixing efficiency and flame stabilization through internal mixing of propellant in it. So, various experiments, such as backlit stroboscopic photography, phase Doppler particle analyzer(PDPA) and mechanical patternator, were performed at several recess lengths to grasp its effect on the spray characteristics of spray angle, breakup length, atomization and mixing. Recess length was normalized to dimensionless recess number and two principal mechanisms of impingement and swirl recovery were introduced to explain its influence on the spray characteristics. The effect of recess on SMD doesn't appear significantly near the recess number where mixing efficiency attains to the maximum, whereas mass distribution and mixing efficiency are changed considerably. Thus, it can be inferred that a certain optimum recess number exists, where mixing efficiency becomes the maximum.

Key Word : Recess, Recess Number, Spray Angle, Breakup Length, SMD, Mass Distribution, Mixing Efficiency

Introduction

Fast atomization, uniform mass distribution and mixing of propellant have great influence on combustion and its efficiency of liquid rocket engine and the injector is very important mechanical device in charge of both atomization and mixing of propellant. Swirl injector is known to have many advantages of atomization, low combustion instability, and wide operating range, compared with other types of injectors, nevertheless its geometric configuration is complex and the manufacturing cost is high. In addition, recess has a good characteristic to improve the mixing efficiency of propellant and flame stabilization.

In the research field of swirl injectors, Lefebvre[1] and Bayvel and Orzechowski[2] published their extensive studies on spray atomization in the various types of swirl injectors. Rizk and Lefebvre[3] conducted a study on the influence of both main dimensions and operating conditions of simplex swirl atomizers on annular liquid film thickness formed at discharge nozzle. Ortman and Lefebvre[4] measured radial mass distribution using one-dimensional line mechanical patternator and introduced the concept of area-weighting factor and equivalent spray angle. Ramamurthi and Tharakan[5] investigated the shape and

* Graduate Student

** Graduate Student, Hyundai MOBIS Research Engineer

*** Associate Professor

E-mail : ybyoon@snu.ac.kr, TEL : 82-2-880-1904, FAX : 82-2-880-2662

disintegration characteristics of swirl annular liquid sheets formed in coaxial injectors and presented two general regimes of annular sheets, tulip and fully developed conical shapes. Han et al.[6] suggested the breakup length of pressure-swirl atomizer. Even though the spray characteristics of swirl injectors such as liquid film in nozzle, spray pattern, SMD, and mixing were widely investigated, these researches are mostly restricted to individual swirl injectors and/or gas-liquid swirl coaxial injectors, and recently more attention has been paid to a study on the influence of jet interaction on the spray characteristics of coaxial injectors[7]. Meanwhile, an extensive researches on the swirl injectors including swirl coaxial injectors were performed in Russia, but their results were rarely published. Thus, the objective of this work is to investigate the spray characteristics of swirl coaxial injectors using liquid-liquid propellants, especially with the variation of recess length.

Swirl coaxial injectors with several tangential entry holes were designed according to the hydraulics theory of swirl injectors. In order to find out the effect of recess on the atomization and mixing characteristics, droplet size, mass distribution and mixing efficiency of propellants were measured using PDPA and mechanical patternator. Also, the spray pattern such as spray angle and breakup length was studied with the direct spray images of backlit stroboscopic photography. In conclusion, the optimal recess length was proposed from the relation between atomization and mixing characteristics.

Experiments

2.1 Swirl Coaxial Injector

The swirl coaxial injectors used in the present study simulate the liquid rocket engine injectors using kerosene and liquid oxygen(LOX). It is designed to be assembled and disassembled with ease and to consider various geometric parameters including recess as shown in Fig. 1. The oxidizer swirl injector is placed at the outer part and the fuel swirl injector is located at the inner part to achieve better atomization; this configuration is generally used in the case that the mass flow rate and momentum of oxidizer are larger than those of fuel.

The inner diameter of the fuel injector is 1 mm and that of the oxidizer injector is 4.25 mm. The gap size between the oxidizer and the fuel injector is 0.625mm. The contraction ratio of the vortex chamber to the injector diameter is 3.6 and 1.51 for the fuel and the oxidizer injectors, respectively. Two tangential entry holes in the fuel injector are 1.1mm in diameter 180° apart and three tangential entry holes in the oxidizer injector are 1.0mm in diameter 120° apart. Under the design specifications, O/F mixture ratio of propellants is 2.6, the stimulants of oxidizer and fuel are water, and the mass flow rates were determined to be 26 g/s for oxidizer and 10 g/s for fuel at the pressure drop of 0.4 MPa. The swirl direction of oxidizer and fuel is the same. Recess length is varied with 4 cases of 3.25, 4.25, 5.25, and 6.25mm.

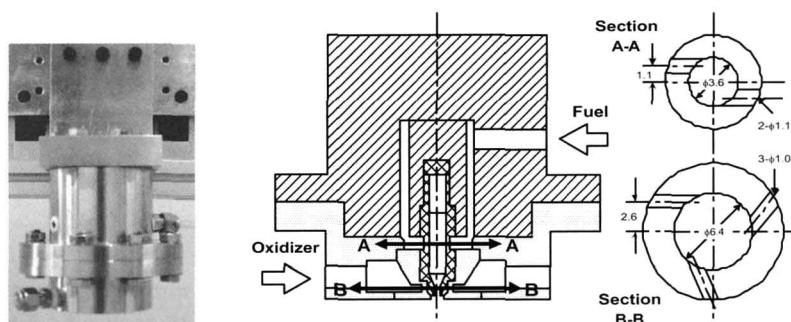

Fig. 1. Schematics of Liquid-Liquid swirl coaxial injector

2.2 Experimental Condition

Water was used as simulants for both fuel and oxidizer in the backlit stroboscopic photography and PDPA experiments. In the mechanical patternator experiment, water was used as a simulant of LOX; kerosene was used for fuel. The mass flow rates and the pressures of simulants were shown in Table 1. Friction losses are assumed to be negligible with the variations of recess. Fig. 2 shows the relation of pressure to mass flow rate, which shows that their relation maintains good linearity in the broad range of operation and that the injectors work near the design point.

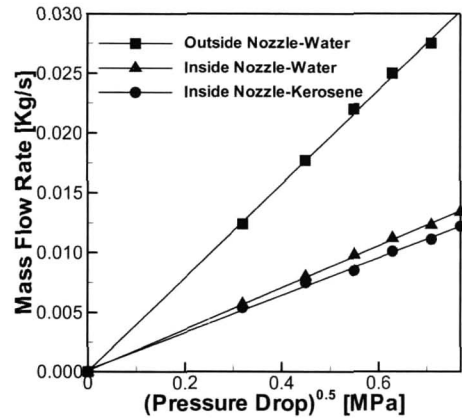

Fig. 2. Mass Flow Rate as a function of Pressure Drop

Table 1. Mass Flow Rate and Pressure Drop

Test	Photography / PDPA		Mechanical Patternator	
	Fuel	Oxidizer	Fuel	Oxidizer
Simulant	Water	Water	Kerosene	Water
Pressure Drop [MPa]	0.4	0.42	0.4	0.35
Massflow Rate [g/s]	11	25	10	23

Results and Discussion

3.1 Recess Number

As mentioned in the previous section, recess is a principal geometric variable of coaxial injectors. In the case of a shear coaxial injector, the dimensionless recess number is defined generally as a ratio of recess length to inner diameter of an outer injector[8]. But, in a swirl coaxial injector using liquid propellants, the spray angle of an inner swirl injector has great influence on the spray pattern, so the spray angle of an inner swirl injector is a critical factor to determine the contact point between the liquid sheet and the liquid film of propellants as shown in Fig. 3. Even if a swirl coaxial injector has a recess configuration, there is no noticeable phenomenon by the recess until the liquid sheet from the inner nozzle doesn't meet the liquid film of the outer nozzle. For this reason, the contact length where the fuel and oxidizer meet is an important factor related to the recess. Therefore, new dimensionless recess number including the effect of spray angle of an inner swirl injector can be defined as the ratio of recess length (L_r) to contact length (L_c) as Eqn. (1).

$$RN(\text{Recess Number}) = \frac{L_r}{L_c} \quad \text{where } L_c = \frac{R_o - R_i}{\tan(\theta_{in}/2)} \quad (1)$$

Here, R_o and R_i are the outer nozzle diameter and the inner nozzle diameter, respectively. θ_{in} is the spray angle of the inner swirl injector. There are theoretically and empirically determined spray angles, but the measured one was used in Eqn. (1).

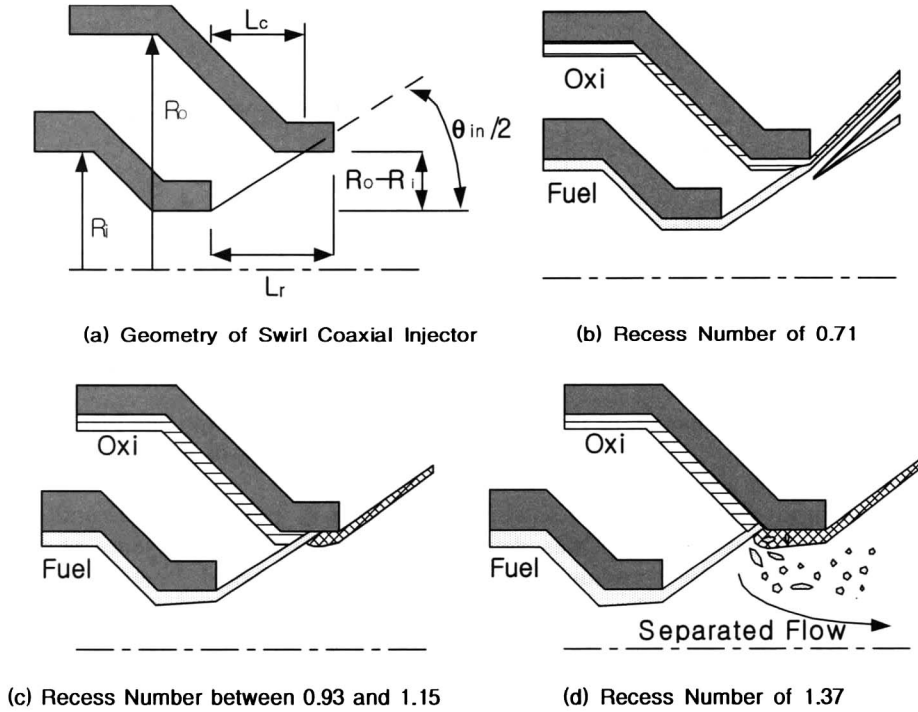

Fig. 3. Impinging Modes of Inner Liquid Sheet by Varying Recess Number

When the recess lengths of 3.25, 4.25, 5.25 and 6.25mm are converted to dimensionless recess number, the corresponding recess numbers are 0.71, 0.93, 1.15 and 1.37, respectively. In the case that recess number is less than 0.71, fuel and oxidizer doesn't meet each other in a recess. When recess number gets to 0.71, the liquid sheet of inner swirl injector collides with and/or meets partially the liquid film's edge of the outer swirl injector as shown in Fig. 3 (b). This is impinging-dominant situation. As for the recess number of 0.93 and 1.15, the inner liquid sheet bumps into the outer liquid film in Fig. 3 (c). In this impingement process, the momentum component of the inner liquid sheet perpendicular to the outer liquid film is blocked temporarily and the liquid film of the coalesced fuel and oxidizer swells up locally. Then, as the swirl recovery phenomenon takes place, the liquid film of the coalesced fuel and oxidizer get thinner and the circumferential velocity increases. Meanwhile, the inner liquid sheet contacts the outer liquid film near the apex between the convergent and straight parts of the outer swirl injector in Fig. 3 (d). In this case, the inner liquid sheet is not merged smoothly with the outer liquid film, because the inner liquid sheet breaks into small drops as soon as it meets the outer liquid film due to the large impingement angle with respect to the convergent wall. Since there is too short length along the oblique wall to merge with the outer liquid flow after the sheet impingement, some amount of the inner liquid sheet is separated from the main merged flow and the shattered small drops pass by through the center of nozzle as shown in Fig. 3 (d).

3.2 Spray Angle and Breakup Length

The recess effects are classified into two parts : impingement effect and swirl recovery effect. The impingement effect occurs when the liquid sheet of the inner swirl injector collides with the liquid film of the outer swirl injector. In the impingement process, the liquid film of fuel and oxidizer becomes unstable and swells up locally. By the swirl recovery effect, the film thickness of the coalesced fuel and oxidizer gets thinner and its circumferential velocity increases. So, the spray angle is increased in proportion to the recess number. These process were investigated by measuring the spray angles and the breakup lengths.

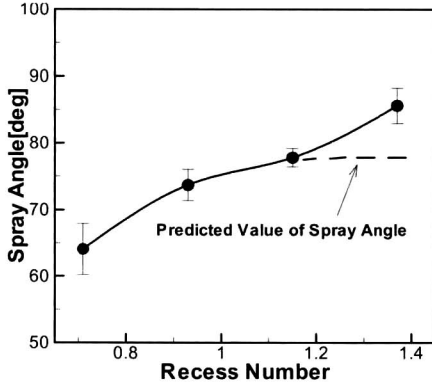

Fig. 4. Spray Angle as a function of Recess Number

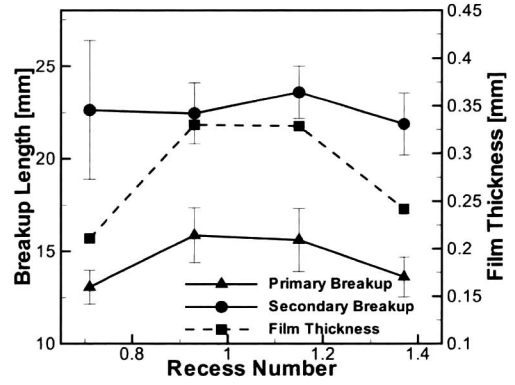

Fig. 5. Breakup Length and Film Thickness as a function of Recess Number

Breakup length was classified into two schemes such as primary and secondary breakup length. The primary breakup length was defined where perforation takes place at the conical liquid sheet and the secondary breakup length where the conical liquid sheet is broken up and drop formation begins. Fig. 4 shows the relation between the recess number and the spray angle of the merged fuel and oxidizer. When the recess number is 0.71, the standard deviation of spray angle is 3.88° . It is the largest value of the standard deviations along the recess number. This phenomenon is caused by the instability of liquid sheet originated from the impingement effect. In the case of recess number of 0.71, the liquid sheet of the inner swirl injector meets the liquid film of the outer swirl injector overall and/or partially irregularly along the circumferential direction. As a result, no swirl recovery effect takes place, and the instability of liquid sheet in this case is more intensive than the others. The swirl recovery effect is augmented as the recess number rises. As the instability of flow diminishes by the swirl recovery effect, the recovered tangential velocity exerts to make spray angle larger. The dashed line extended from experimental data is the predicted spray angle beyond the recess number of 1.15 without the flow separation. When the flow separation occurs, the momentum of the outer flow is increased comparatively due to the less momentum of the inner flow that is exerted to the outer sheet, and the spray angle becomes larger. Resultantly, the spray angle comes close to the intact spray angle of the outer swirl injector which is about 107° .

Fig. 5 shows that primary breakup length decreases as recess number increases. This result can be understood as similarly with impingement and swirl recovery effects on spray angle. Increased recess number augments the tangential velocity of the coalesced fuel and oxidizer. The augmented tangential velocity makes the liquid film thickness thinner and spray angle larger. Then breakup length is shortened. In Fig. 5, the film thickness of the merged fuel and oxidizer is determined by using Eqn. (2) suggested by Han et al[6]. It was modified for the conical sheet spray based on the plane sheet's film thickness equation proposed by Clark et al[9]. In Eqn. (2), L and θ are the measured primary breakup length and the spray angle, respectively. B is 3 determined with the test result. h is the film thickness. ρ_g and ρ_l are environmental gas density and liquid density, respectively. U is a sheet velocity. σ is liquid surface tension and η is a wave amplitude and $\ln(\eta/\eta_0)$ is 12 as a constant[9].

$$h = \frac{L^2 \rho_g^2 U^2}{B^2 \rho_l^2 \sigma \ln(\eta/\eta_0) \cos \theta} \quad (2)$$

The film thickness in Fig. 5 is based on the test results and its tendency is similar to that of primary breakup length. As recess number increases except the recess number of 0.71,

both film thickness and breakup length decrease. When the recess number is 0.71, only impingement effect acts on the fuel and oxidizer and it makes the coalesced fuel and oxidizer highly unstable and breakup length shorten.

3.3 Atomization

The conical sheet goes by narrower flow area as recess number increases due to the recovered tangential velocity, as shown in Fig. 6. The relative volume flux means the volume flux normalized by the maximum value and the peaks of relative volume flux move outward in the radial direction as the recess number increases. In the case of recess number 0.71, there is no specific peak value of relative volume flux, and the spray is distributed in the broad range of radial direction. When the recess number is 1.37, it has the same spray pattern with the separated flow that peak of relative volume flux is located both at the small and the large radial distance.

PDPA is a point measurement device and the measured SMDs are local values. So, mean SMD was suggested for the representative SMD. As shown in Eqn. (3), mean SMD was weighted averaged with flow area and volume flux and is shown in Fig. 7. A_j in Eqn. (3) is the ring shape area.

$$\overline{SMD} = \frac{\sum VF_j \cdot A_j \cdot SMD_j}{\sum VF_j \cdot A_j} \quad (3)$$

SMD was measured at two axial distance of 50 and 70mm. The dashed line is the averaged data of the axial distance at 50 and 70mm in Fig. 7. As the recess number increases, SMD is decreased. This can be explained by the reduced film thickness of the coalesced fuel and oxidizer due to the swirl recovery effect in a recess since SMD is proportional to the power of the film thickness[1]. Mean SMD at RN=0.71 is similar to that of recess number of 0.93. This means that the impingement effect is a predominant factor of the breakup of hollow conical sheet in these region. On the other hand, mean SMD at RN=1.15 is analogous with that of recess number of 1.37 because the swirl recovery effect exerts prevalingly in these cases. But the differences between these values are only about 10%.

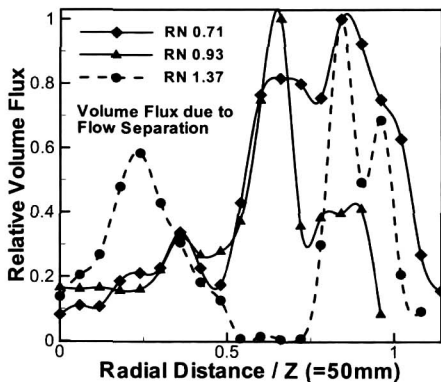

Fig. 6. Relative Volume Flux as a function of Normalized Radial Distance at Z=50mm

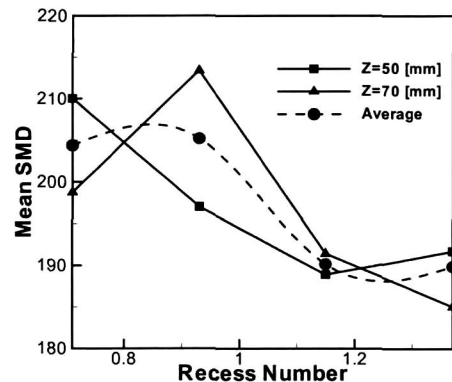

Fig. 7. Mean SMD as a function of Recess Number

3.4 Mixing Efficiency

A cold flow mixing test can be frequently used as a preliminary test for predicting potential performance of rocket engine injectors. Combustion efficiency is also affected by the

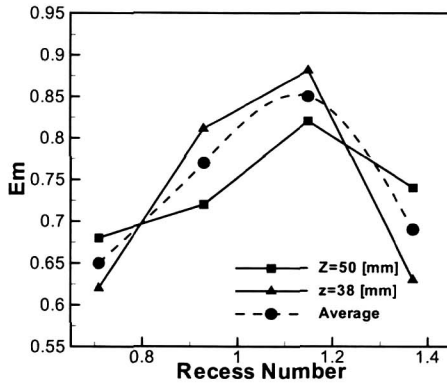

Fig. 8. Recess Number vs. Mixing Efficiency

Fig. 8 shows the results of mixing efficiency. The mixing efficiency has the maximum value at the recess number of 1.15. The separated flow causes the abrupt decrease of mixing efficiency in the recess number of 1.37. So, optimal recess number is 1.15 with the viewpoint of the atomization and the mixing efficiency.

Conclusions

The objective of this research is to find out the mechanism of recess effects and the optimum value of recess. To present the recess effect on the spray characteristics, experimental data such as the spray shape and angle, the breakup length, atomization, mass distribution and mixing efficiency were analyzed. The optimum recess was obtained with the viewpoint of the atomization and the mixing efficiency results. The conclusions can be summarized as follows.

1. Recess number can be a principal parameter that expresses the spray characteristics including the recess effect. The recess number covers a range of 0.71~1.37 that includes from the negligible recess to the excessive recess under the designed injector.

2. The recess effect is classified with two mechanisms of impingement and swirl recovery effect. The impingement effect initiates both merging and internal mixing of propellant in a recess and the swirl recovery effect restores the kinetic energy of the coalesced fuel and oxidizer.

3. The optimum recess exists around the recess number of 1.15. This can be explained by impingement and swirl recovery effect.

Acknowledgement

This research was supported by the National Research Laboratory Project program (M1-0140-00-0058). The authors wish to acknowledge these financial supports.

References

1. Lefebvre, A. H., Atomization and Sprays, Hemisphere Pub. Co., Newyork, 1989.
2. Bayvel, L., and Orzechowski, Z., Liquid Atomization, Taylor and Francis, 1993.
3. Rizk, N. K., and Lefebvre, A. H., "Internal Flow Characteristics of Simplex Swirl Atomizers," AIAA. J. Propulsion. Power, Vol. 1, No. 3, 1985, pp 193-199.

uniformity of liquid-phase mixing. Thus, the spatial distribution of mass and mixture ratio have a great influence on combustion efficiency.

The mixing efficiency was calculated from the local mixture ratio in each lattice cell of mechanical patternator by using Eqn. (4) suggested by Rupe et al[10]. Here, M_t is the total collected mass and m_l is the locally accumulated mass in each cell. R is the overall mixture fraction, and r is the local one in each cell. \bar{r} is used when $r \geq R$.

$$E_m = 1 - \left[\frac{\sum_0^R m_l (R - r)}{M_t R} + \frac{\sum_0^{\bar{r}} m_l (R - \bar{r})}{M_t (R - 1)} \right]$$

$$\text{where } R = \frac{M_{t, Ox}}{M_{t, Fuel} + M_{t, Ox}}, \quad r = \frac{m_{l, Ox}}{m_{l, Fuel} + m_{l, Ox}} \quad (4)$$

4. Ortman, J., and Lefebvre, A. H., "Fuel Distribution from Pressure-Swirl Atomizers," *J. of Propulsion and Power*, Vol. 1, No. 1, January-February 1985.
5. Ramamurthi, K., Tharakan, T. John, "Experimental Study of Liquid Sheets Formed in Coaxial Swirl Injectors," *Journal of Propulsion and Power*, Vol.11, No.6, November-December 1995.
6. Han, Z., Parrish, S., Farrell, P. V. and Reitz, R. D., "Modeling Atomization Processes of Pressure-swirl Hollow-cone Fuel Sprays," *Atomization and Sprays*, vol. 7, pp. 663-684, 1997.
7. Sivakumar, D., and Raghunandan, B.N., Hysteretic Interaction of Conical Liquid Sheets from Coaxial Atomizer : Influence on the Spray Characteristics, *Physics of Fluids*, Vol. 10, No. 6, June, 1998, pp. 1384-1397.
8. Gill, G.S., A Qualitative Technique for Concentric Tube Element Optimization, Utilizing the Factor(Dynamic Head Ratio-1), 16th AIAA Aerospace Science Meeting, 78-76, January, 1978.
9. Clark, C. J. and Dombroski, N., "Aerodynamic Instability and Disintegration of Inviscid liquid Sheets," *Proc. Roy. Soc. Lond. A*, Vol. 329, 1972.
10. Rupe, J.H, "The Liquid-Phase Mixing of a Pair of Impinging Stream", Jet Propulsion Lab, Progress Rept. 20-195, California Inst. of Technology, Pasadena, CA, August 6, 1953.